

# TANKBOT BUILDING INSTRUCTIONS

## REQUIRED PARTS

- 4** 1x16 TECHNIC Brick **A**
  - 4** Connector Peg w/friction **B**
  - 4** 8-stud Axle **C**
  - 2** 2x4 Plate w/holes **D**
  - 4** 24-Tooth Gear Wheel **E**
  - 4** 1 1/2 Connecting Peg **F**
  - 4** Connector Peg **G**
  - 2** 1x4 Plate **H**
  - 2** Gear Motor **I**
  - 12** Full Bushing for Cross Axle **J**
  - 4** 2x2 Brick **K**
  - 4** 1x8 TECHNIC Brick **L**
  - 2** Connecting Lead **M**
  - 2** 16-Tooth Gear Wheel **N**
  - 1** RCX **O**
  - 4** Rim for Belt **P**
  - 2** Caterpillar Belt **Q**
  - 8** 2x8 Plate w/holes **R**
- Parts not to scale*

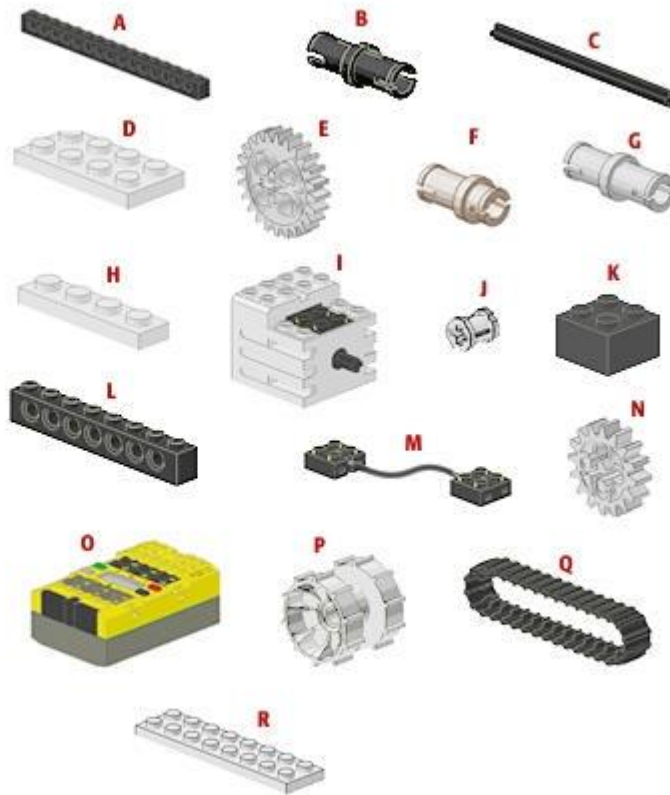

Begin with two 1x16 TECHNIC bricks.



2 of 24

Insert four black connector pegs w/friction.



Add two 1x16 TECHNIC bricks.

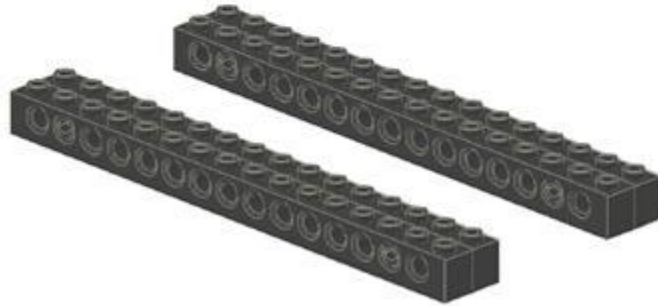

Insert four 8-stud axles.



Add 6 full bushings (for cross axles).



Add two 24-tooth gear wheels.



Add four full bushings.

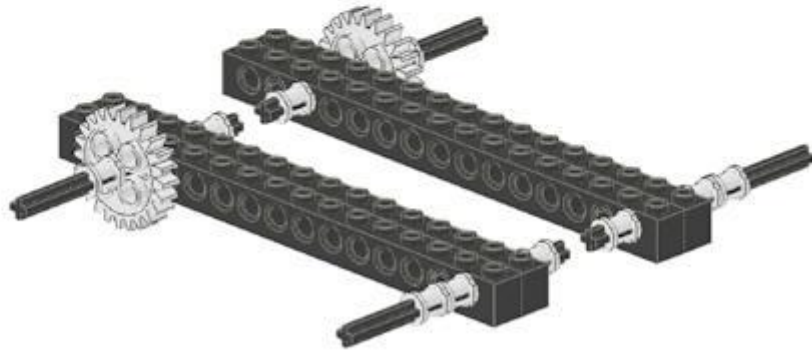

Add two 2x8 plates w/holes.



Add four 2x8 plates w/holes.

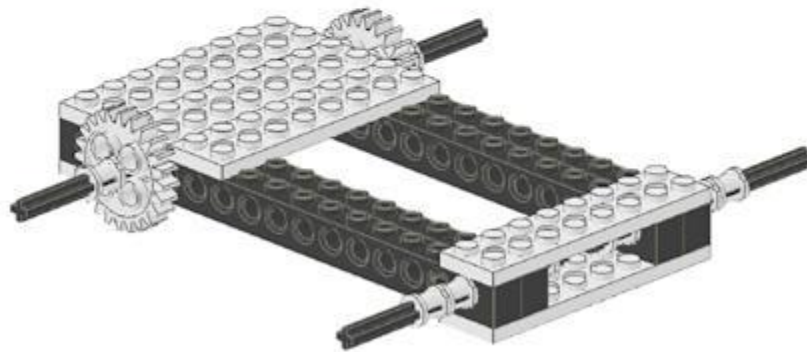

Add two 1x4 plates.

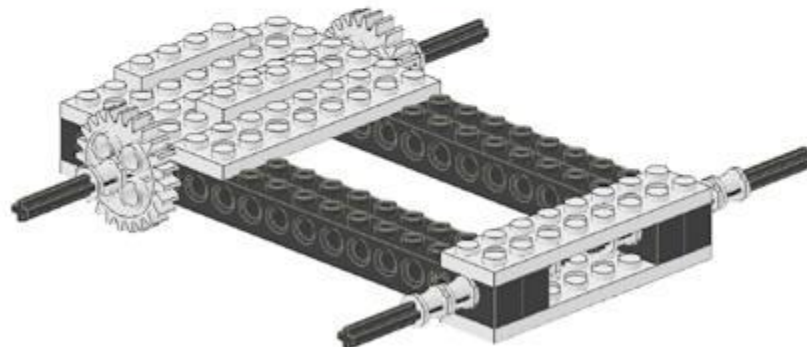

Add two 2x4 plates w/holes.

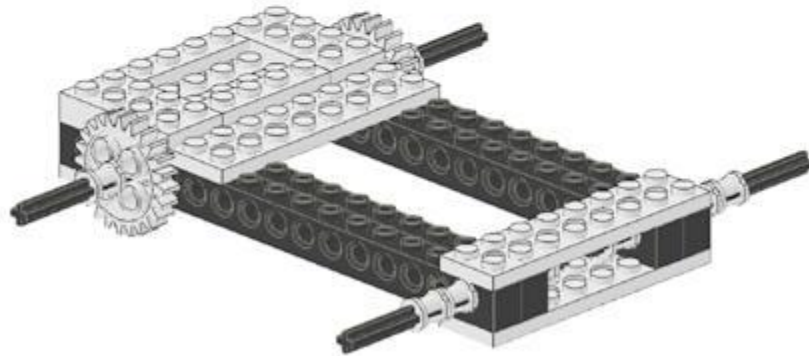

Add two gear motors.

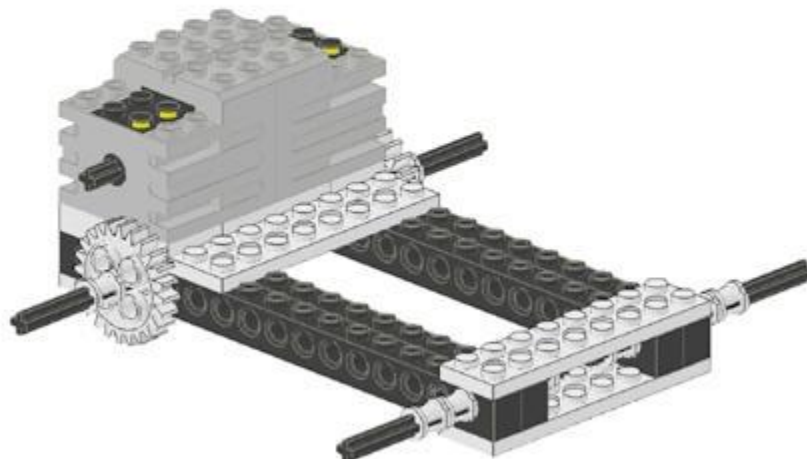

Add a 24-tooth wheel gear to each gear motor axle.



Add four 2x2 bricks.

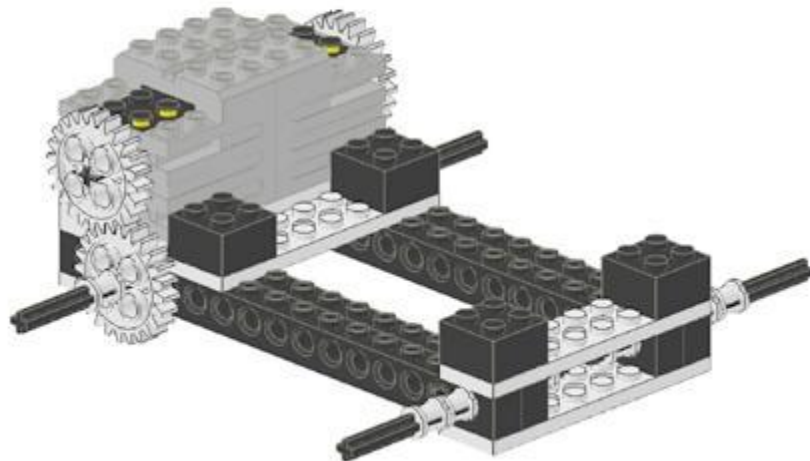



Add two 2x8 plates w/holes.

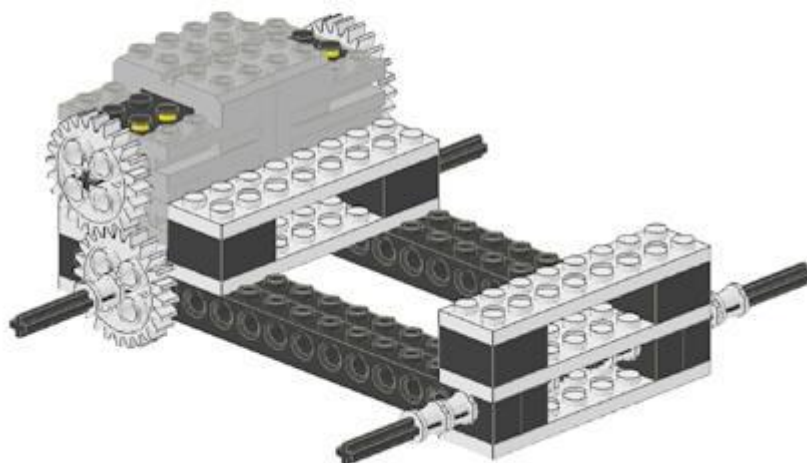

Attach an RCX to the chassis.

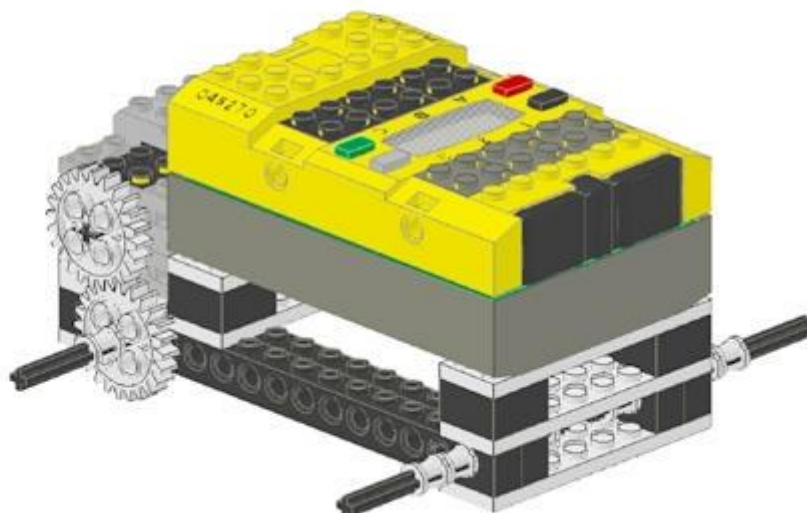

Add four connector pegs: two on the left side and two on the right side.

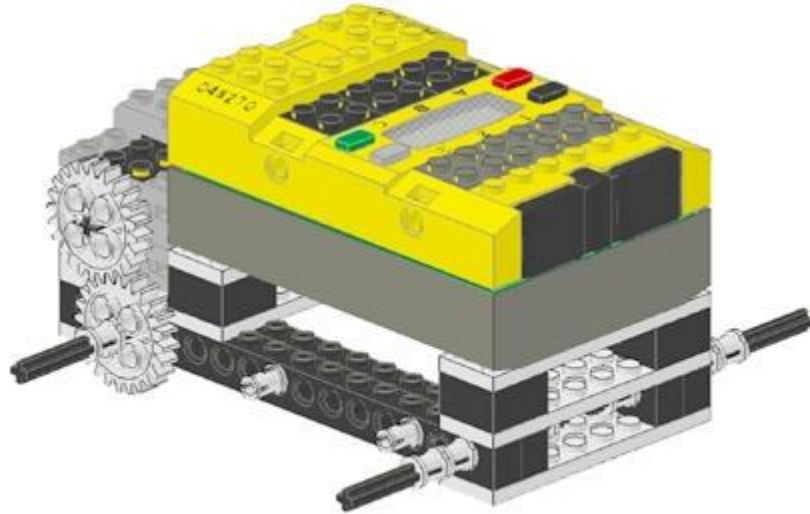

Add four 1½ connecting pegs to the RCX: two pins on the left side, two pins on the right side.

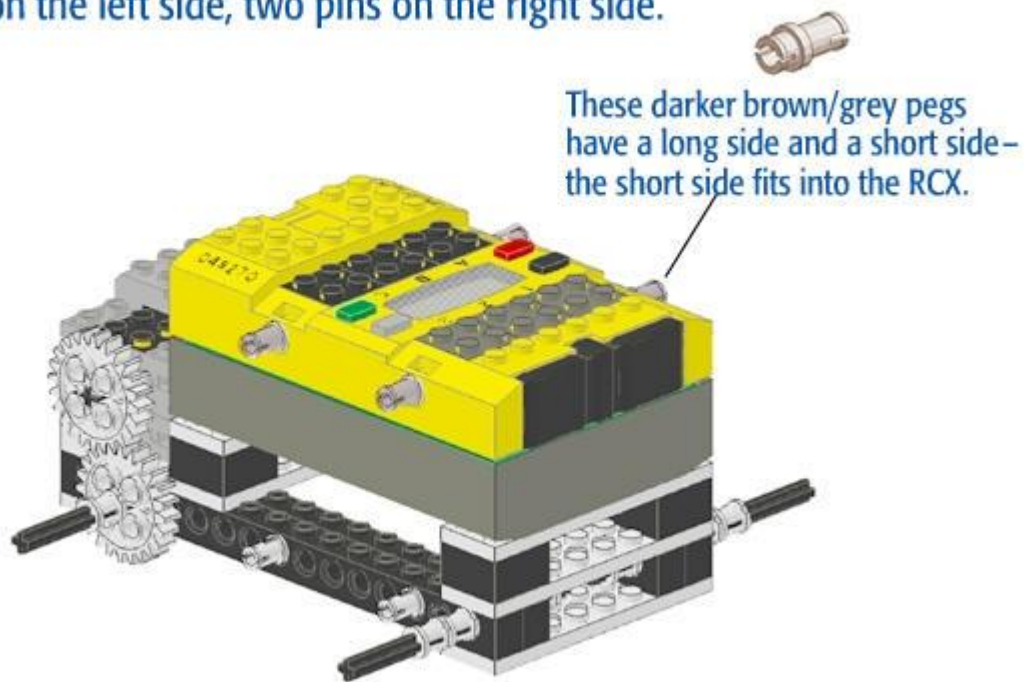

Add four 1x8 TECHNIC bricks.

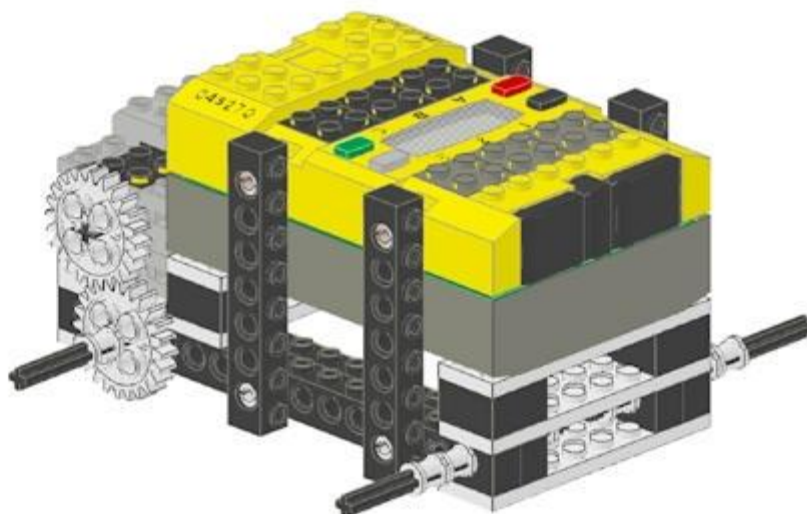

Add four white rims for belts: one per axle.

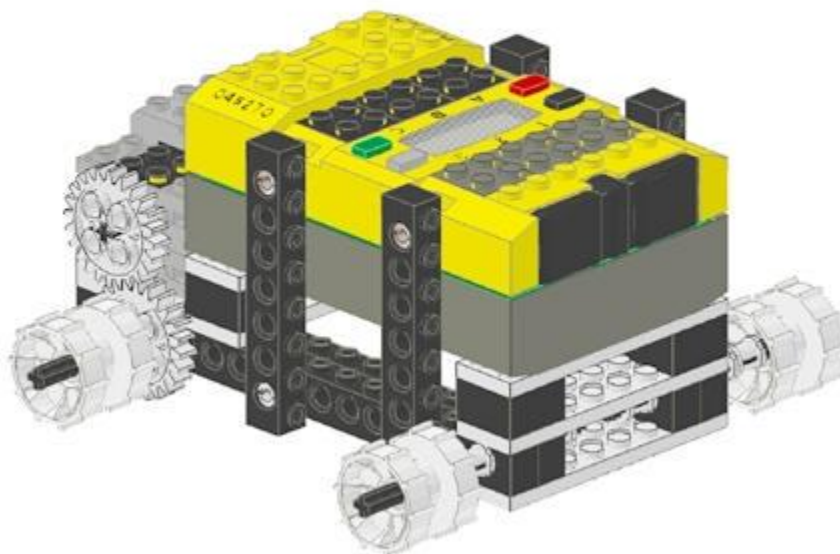

Add full bushings to the two front axles to stop the rims from falling off. Insert a 16-tooth gear wheel inside the rim on each rear axle.

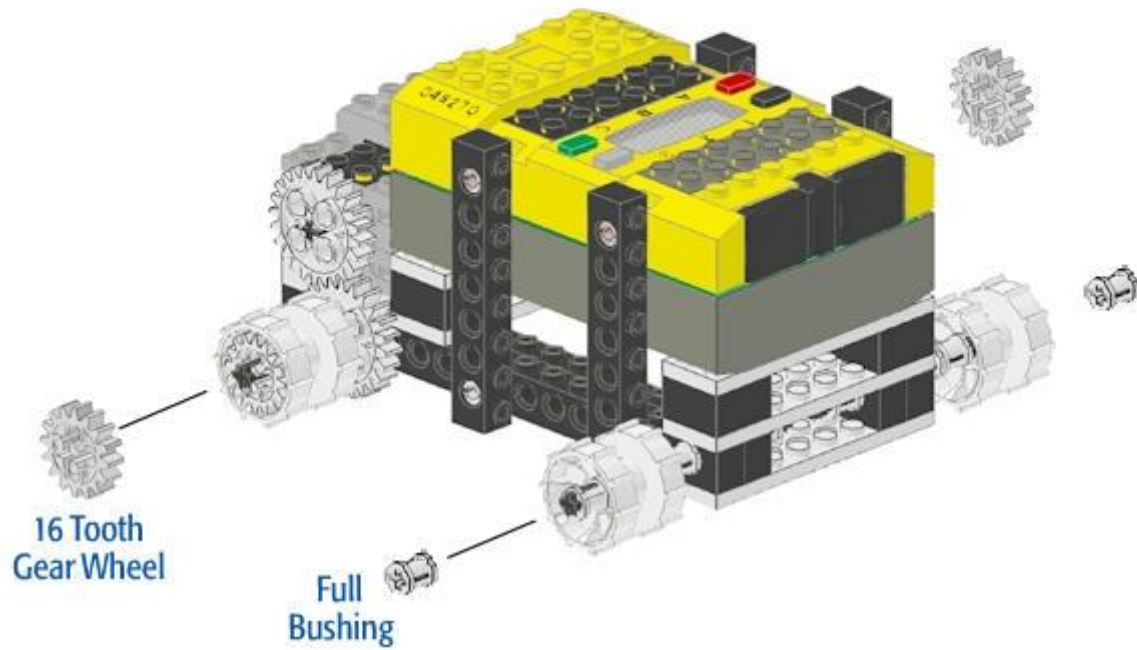

22 of 24

Add two caterpillar belts (treads).

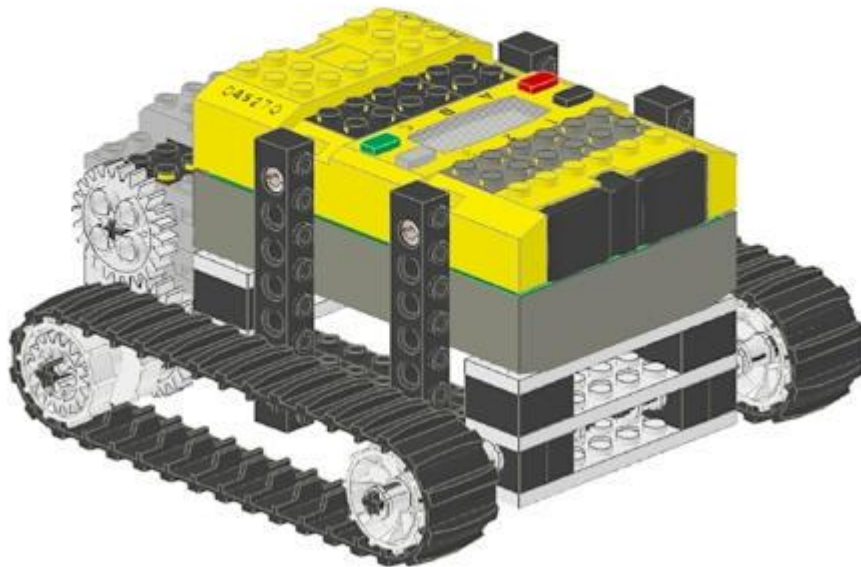



## Add connecting leads to connect the motors to the RCX.

Be sure to connect the leads as shown below. If the cables are arranged differently you might change the polarity of the motors. This could cause the robot to move in a different direction from what you expect.

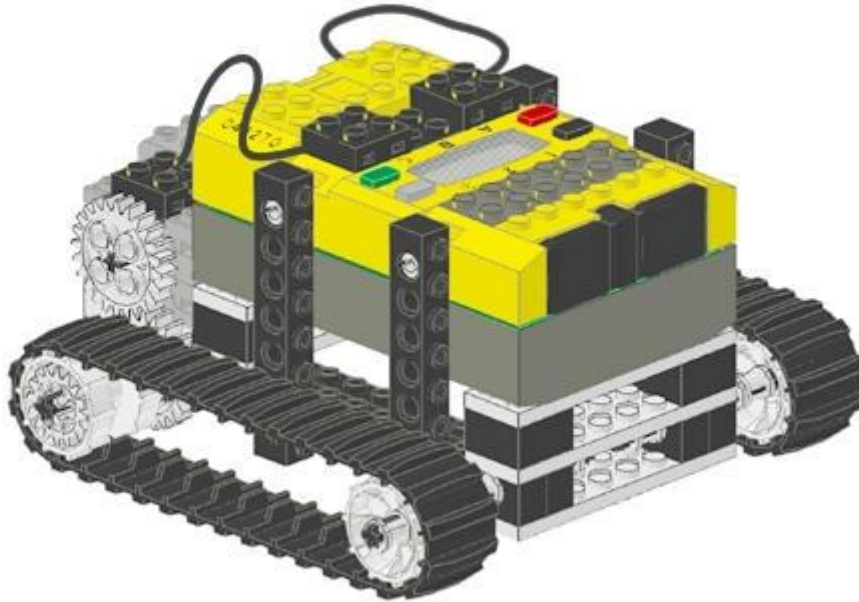

Your TANKBOT is complete.